

LABOTEK

Volumetric Dosing Units
MC12/MC18/MC30®



 **Labotek**
Power in Plastics

Volumetric Dosing Units MC12/MC18/MC30

All units are equipped with unique dosing cylinder and extreme accurate stepper motor. The dosing cylinder releases the colour in a steady flow. The stepper motor ensures maximum control with no stoppages and no pulsating. There is no other method in the world as accurate as this.

MC12 Economy

- Manual adjustment of metering speed and time
- The unit also works in relay mode for extrusion applications
- 4-piece 7 segments LED display
- Keypad Operated
- Keypad Lock function

MC18 Synchronic

Like the MC12 +

- Auto Synchronization to extruder speed
- Integrated hopper loader control
- Alarm output

MC30 Auto-Calibrate

- Integrated hopper loader control
- Warning and Alarm output
- Automatic material calibration function
- Recipes function
- Communication TCP/IP
- Menu guided control and graphic LCD display with backlight
- Control for Extrusion:
 - % Setpoint adjustment
 - Auto Synchronization to extruder speed
- Control for Injection Molding:
 - % Setpoint adjustment
 - Auto metering time synchronization

MC12/MC18/MC30, Technical Specifications

Power supply: 80-260 V, 50/60 Hz, by integrated automatic voltage selector

Power consumption: 80 Watt maximum

Input signals: Potential free or 24 VDC start input

Capacity ranges: 0.07-180 kg/h *

*) Measured with normal granular masterbatch 0.8 kg/dm³

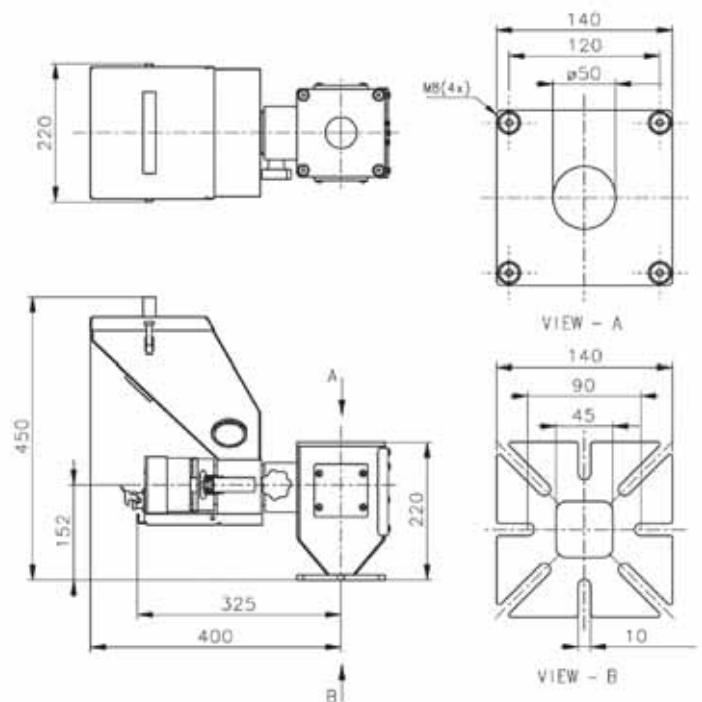

Compact Design

Labotek A/S

Stroebjergvej 29, DK-3600 Frederikssund
 Tel +45 4821 8411 | Fax +45 4821 8000
 info@labotek.dk | www.labotek.com

