

Labo-Net

Advanced Touch Screen Control for
Materials Handling Systems



Labo-Net

Introduction

Labotek Labo-Net series takes full control of all materials handling requirements. A user-friendly interface via 12" touch screen provides automatic control of drying and/or conveying of raw materials.

The Labo-Net system is supplied in wall mounted cabinet and enables great visual appearance of the features. Labo-Net is able to handle Labotek Energy Saving Systems & Labotek frequency controlled vacuum stations as standard. The Labo-Net uses network communication between system components via the well known, flexible and very reliable AS-Interface & Siemens Profi Net.

The Labo-Net Series offers...

- Unmatched flexibility in configuration options, giving superior visual appearance
- Max 93 stations, up to 40 stations as DH standard
- Labotek Energy Saving System (LESS)
- Air Flow Regulation System (AFRS)
- Control of up to 3 Central Dryers type DFD as standard
- Standard Material Data Base with 500 recipes
- Trend curve history for each drying hopper (DH) of temperatures & dew points
- Max 5 Vacuum stations with significant energy savings via frequency controlled blower
- Full control of all parameters for each station
- Personalized descriptive texts and plain alarm texts
- Ease of use, no need for special training
- Internet connectivity for remote access included (VPN)
- Software prepared for Labotek Gravi-Dryer option
- Software prepared for optional Gravimetric dosing/mixing units
- Comprehensive 3 year warranty

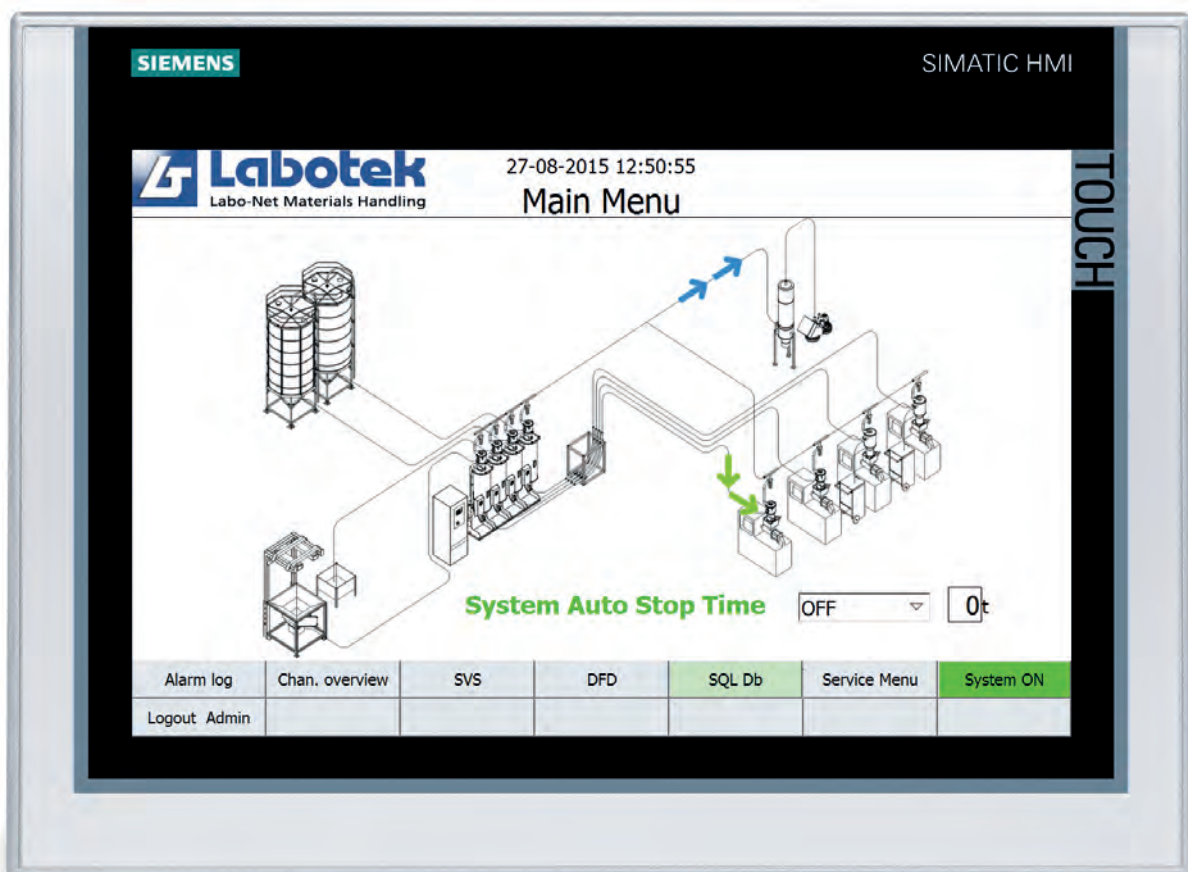

Drying

The Labo-Net is capable of controlling up to 40 Drying Hopper Stations (DH) and up to 3 Desiccant Flex Dryers (DFD) as standard. Desiccant air circulates in a closed system.

The air is dried in desiccant beds where the dew-point temperature is lowered to -40°C or better. The dry air heating element in each DH is used to heat the drying air to the required temperature before, via the air separator it is distributed in the DH. After the drying air has heated the raw material and transformed the moisture to water vapour, it is led back to the desiccant dryer DFD, absorbing the humidity. Labo-Net also includes a drying data base for parameters.

Labotek is considered as one of the leading suppliers within drying technology, using only energy saving technologies. Please consult our staff for more information on Labotek energy calculation programme to obtain exact Labotek energy consumption for drying.



Labotek Energy Saving System (LESS) and Air Flow Regulation System (AFRS) for Drying Hoppers DH

Labotek Energy Saving System (LESS) has been designed to achieve energy savings of the drying air that is fed to the drying hopper, as well as providing protection against over drying.

Air Flow Regulation System (AFRS) is allowing adaptive airflow control for each Drying hopper. This feature, combined with our optional frequency inverter in the DFD series, enables a dramatic reduction in energy consumption.

The current drying temperature can be lowered by an optionally selected number of degrees from the set drying temperature. Lowering of the temperature and reset to normal drying temperature are automatically controlled by the return air temperature at each Drying Hopper DH. The LESS system in Labo-Net control operates using relative lowering of drying temperature after reaching the set value. Temperature reduction will begin when the material has been dried.

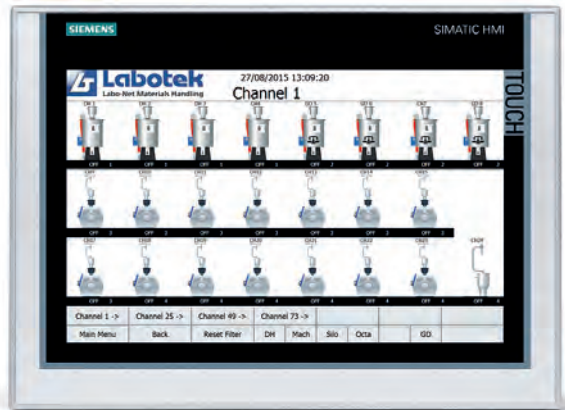

Overview of Drying Hoppers



Individual Drying Hopper data selection



Setup menu and status for Drying Hopper

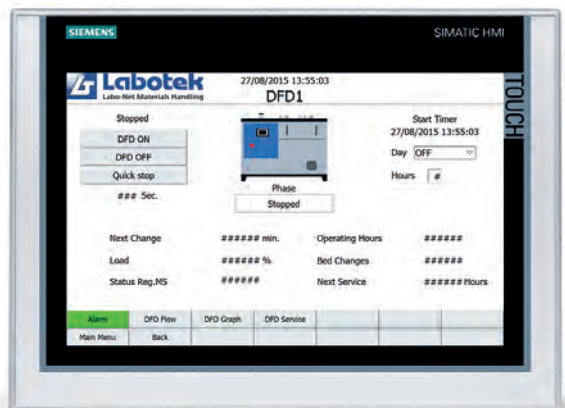

Central Desiccant Dryer overview

Conveying

Labo-Net may control up to 93 vacuum receivers and up to 5 vacuum stations as standard.

Suction time, line clearing time, suction address and air speed frequency is adjusted direct on screen, either via keyboard pad or drop down boxes.

Vacuum station no is saved & selected per receiver, therefore one system could comprise as many receivers as the capacity of blower can safely manage.

Labo-Net also features full control of a proportioning valve for introducing two materials to vacuum receiver, i.e. Regrind & Virgin. The proportioning is set as % of main material and allows several mix of the Regrind into virgin for material layering into the vacuum receiver. Operator can scroll between station selection as required.

Labo-Net control has built-in control of suction address, where a pneumatic slide valve under a drying hopper is operated, securing a safe and self cleaning conveying cycle, leaving no dried material residue after a conveying cycle.

The frequency controller is set in % air speed; here-with each station may have its individual air speed setting, depending on material being conveyed. Huge energy savings may be obtained through our series of frequency inverters, raw materials are gently conveyed and hardware piping systems/hoses have increased lifespan.



Gravimetric Dosing

The Labo-Net Weight control is able to handle control, logging and monitoring of several types of gravimetric dosing/mixing systems, such as Gravi-Master.



Graphic system overview



Production machine



Vacuum station 1-5 menu

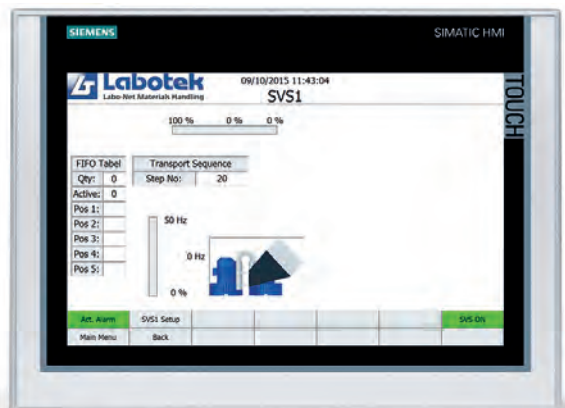

Individual vacuum station menu

Technical Data

The vacuum station set up menu is prepared for several central filter cleaning options, such as dust cyclone, self purifying filter or Blow Back Valve. Between cycles the individual stand by frequency may be selected leaving each vacuum station running at i.e. 10 Hz while waiting for next station to call for material.



Full service menu with timers and complete alarm log

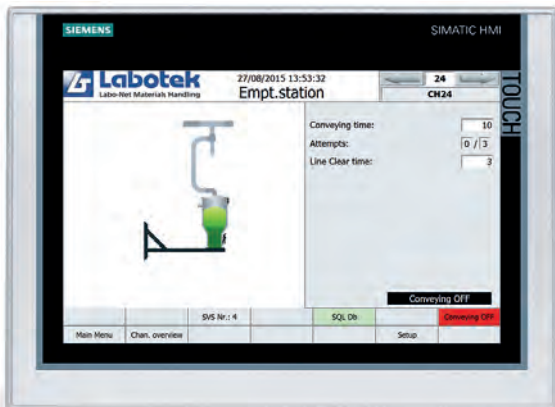

Up to 3 Emptying stations for rapid purge of DH

Dimensions

Description	Dimensions
Labo-Net 62/12" & Labo-Net 93/12"	L 600 x W 600 x D 250 mm

Options

Pos.	Description	LT no.
1	Warning lamp 24 V AC (fitted on top of control)	202041
2	Warning lamp 24 V AC (with 10 m cable for remote location)	203578
3	Local On/Off at production machine	204988
4	ASi Airbox for each vacuum receiver SVR/PGT	752024
5	Labotek ASi Combi module for each Drying Hopper DH	207217
6	ASi Yellow control signal cable (Max 100 m per segment)	605042
7	ASi Black 24 V supply cable (for Combi Module pos 5)	605092
8	ASi Extension kit (used when cable length exceed 100 m)	207410

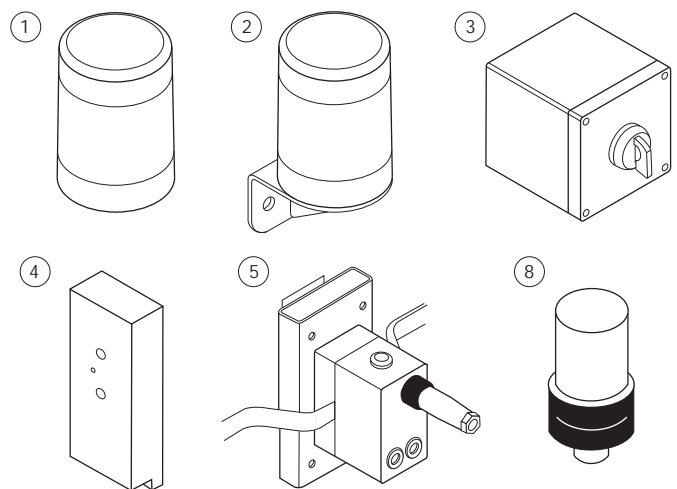

Product specifications

Part no.	Description	No of stations DH/SVR or Machine/SVR	Max No of Drying Hopper stations DH & DFD	Max No Vacuum Stations	Vacuum station Frequency controller
101382	Labo-Net 62/12" 230 V / 50-60 Hz	62	40 / 3	5	Yes
101384	Labo-Net 93/12" 230 V / 50-60 HZ	93	40 / 3	5	Yes



Labotek A/S
Stroebjergvej 29
DK-3600 Frederikssund

Representative

+45 4821 8411
info@labotek.dk
www.labotek.com