

# Gravi-Dryer®

Advanced material &  
Energy management



**Labotek**  
Power in Plastics

# Gravi-Dryer®

## Imagine...

- A drying system that ONLY uses the energy required for the actual consumption, providing rapid return of investment (ROI).
- Full tracking record of processed drying data for material- and quality management.
- Preventing over and under drying of raw materials.
- Auto emptying of a drying hopper after production.

Labotek is manufacturing a wide range of dry air drying systems, depending of the product being dried. Our comprehensive range of desiccant drying units is starting from 100 m<sup>3</sup>/h and extends up to 8500 m<sup>3</sup>/h.

Drying hoppers are sized from 15 litres up to 12000 litres. Labotek is offering premium solutions in drying, either as single drying units or large centralised drying system solutions.

The philosophy behind Labotek's drying equipment is simple:

To achieve continuous drying without costly interruptions to production, made possible through high quality equipment, operating at lowest possible emissions.



A gravimetric drying hopper is capable of tracking the filling & discharge of plastic raw materials via the "gain in weight" & "loss in weight principles" in the most energy efficient ways available. The system ONLY uses the energy required for the actual material type and consumption, therefore NO excess energy is used.

The Gravi-Dryer® has proven weighing accuracy down to +/- 0.5% and enables full control and tracking history of the individual material consumption for each drying hopper and will ramp up and down according to the actual consumption. The filling of a drying hopper via the "ramp up principle", eliminates the risk of over drying the raw materials. Furthermore when material usage is lowered, the central desiccant dryer will perform automatic adjustment of dry air flow through the built in frequency control. At end of production, the Gravi-Dryer is capable of lowering the material volume in Drying Hopper, via "Ramp Down Principle".

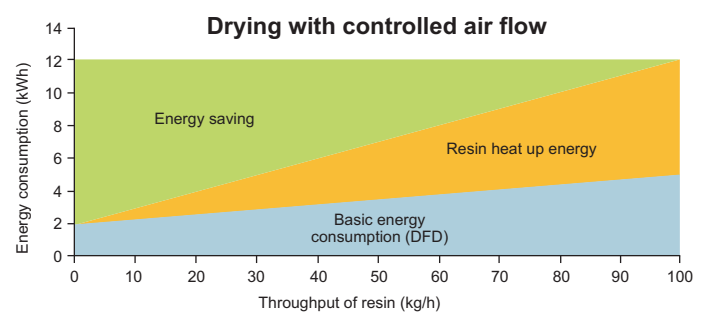
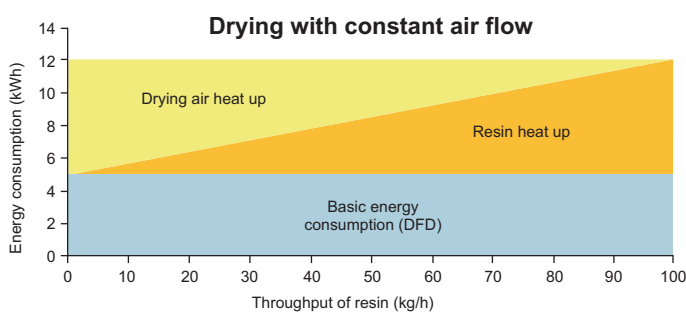
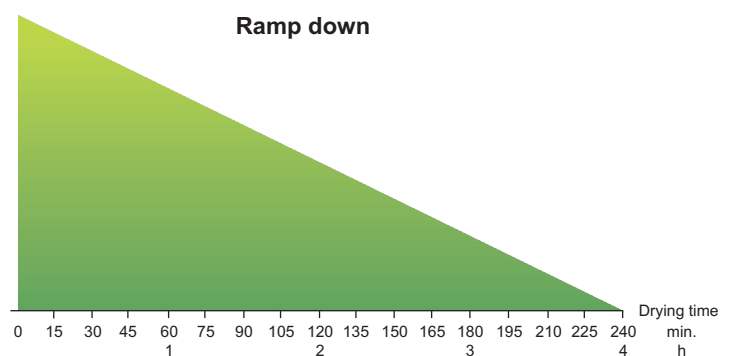
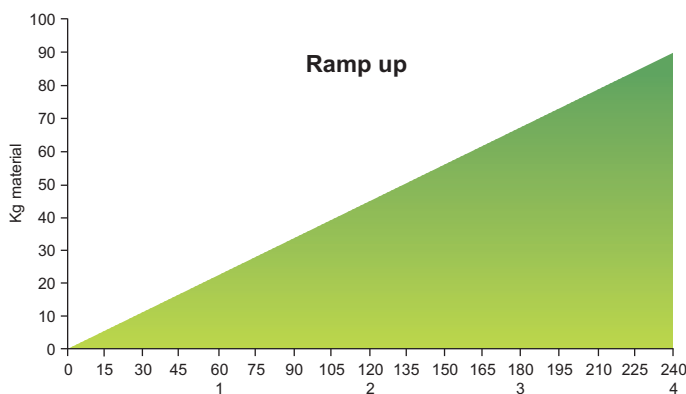

Fig. 1: Standard dryer with constant air flow in 100 kg drying hopper.

Fig. 2: Dryer with inverter which controls the air flow in 100 kg drying hopper.

## Labo-Net for Gravi-Dryer®

The Labo-Net control system takes full control of the Gravi-Dryer® material handling requirements. A user-friendly interface via 12" touch screen provides automatic control of drying and conveying of raw materials. The Labo-Net system is supplied in wall mounted cabinet and enables great visual appearance of the features. Labo-Net is able to handle the Gravi-Dryer® systems & the Labotek frequency controlled vacuum stations as standard. The Labo-Net uses network communication between system components via the well known flexible and very reliable AS-Interface & Siemens Profi Net.

The filling of each Gravi-Dryer® is fully automated and adjusted accordingly to configured material usage in the process machinery connected. The Labo-Net control monitors any variation to the material usage. By the use of the optional SQL database, the historic data may be retrieved, such as events and alarms.

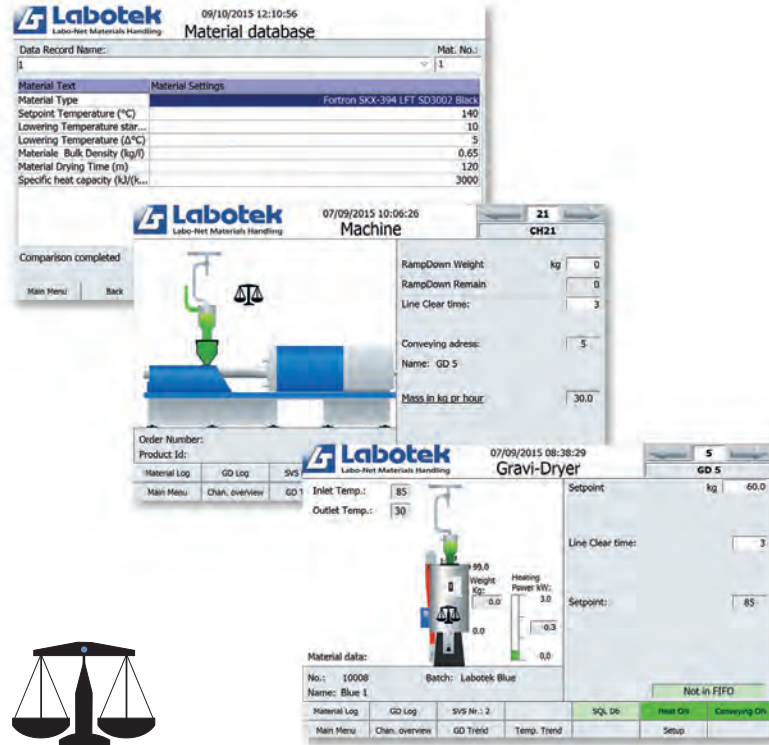

## Labo-Net for Gravi-Dryer® offers...

- Unmatched flexibility in configuration options, giving superior visual appearance.
- Max 93 stations.
- Protection against over and under drying of materials (ramp up & ramp down).
- Control of up to 3 Central Desiccant Flex Dryers (DFD).
- Standard Material Data Base with 500 recipes.
- Labotek Energy Saving System (LESS).
- Optional SQL database
- Air Flow Regulation System (AFRS).
- Trend curve history for each drying hopper (DH) of temperatures & dew points.
- Auto detection of consumption changes, enabling massive reductions in energy consumptions.
- Full control and documentation of all drying parameters for each station (SQL option).

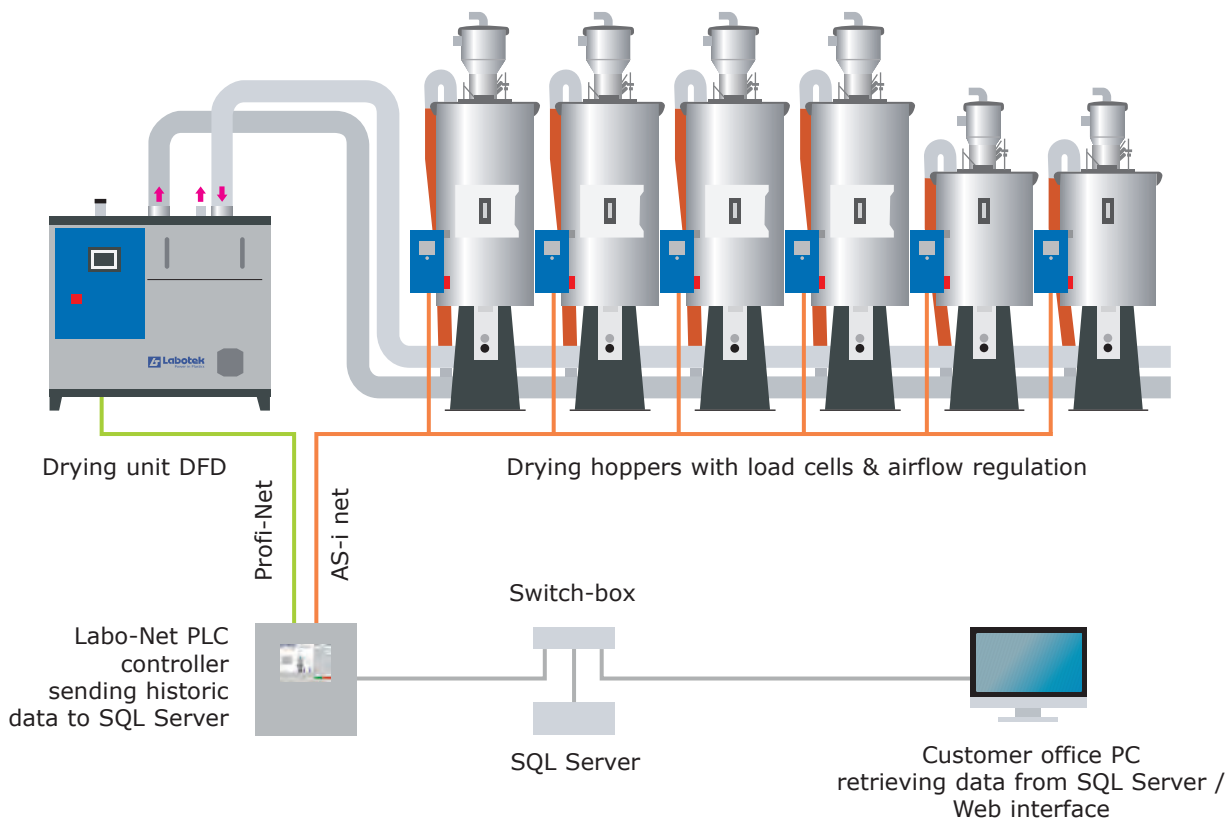

## External Heat Recovery (EHR)

External Heat Recovery (EHR) operates with external hot water, ex from compressor cooling, power utility or other processes in the plant.

The EHR enables to utilize the hot water and transfer into process air in Labotek drying systems, through high efficient air/water heat exchange devices.

Energy saving are massive and depending on the temperature/flow of the water available, savings of electrical power up to 85% are achievable.

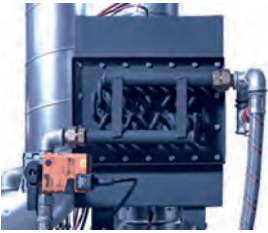

Please consult your local Labotek representative for detailed calculation on energy savings and further product information about this unique energy preserving technology.

## Constant air flow Vs. controlled air flow. What is the benefit?

Below pictures show the internal temperature of a Drying Hopper during the 3 scenarios.

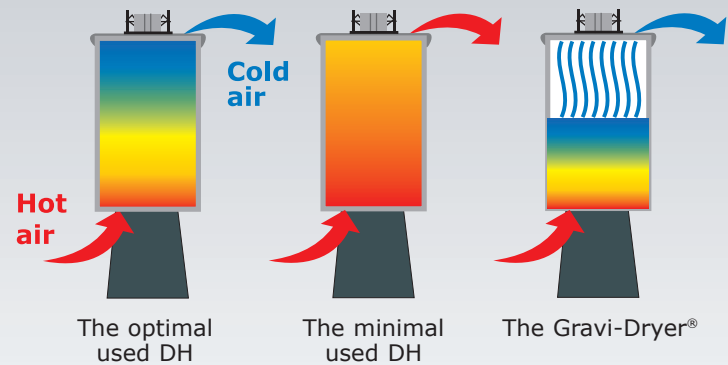

## Desiccant Flexible Dryer for Gravi-Dryer®

The Desiccant Flexible Dryer (DFD) series is aiming to dry one or more raw hygroscopic plastics materials simultaneously. Through an airtight interconnecting ducting system installed between the DFD & DH, makes dehumidification of the air possible due to a twin bed desiccant assembly which contains molecular sieve absorption material.

Regeneration of the drying medium takes place in a closed cycle, thus ensuring optimal dew points and lowest possible energy consumption.



DFD 300-450

A unique "moisture dependent regeneration system", enables the dryer to regenerate the molecular sieves depending on the moisture levels being absorbed, therefore the time between bed changes is flexible and dryer is only utilizing the regeneration energy required, or after a set dew point. The range is capable of supplying dew point down to  $-40^{\circ}\text{C}$  or better. The dryer is fitted with Siemens PLC with Profi-Net connection gate to Labo-Net control.

## Drying Hopper for Gravi-Dryer®

A complete standard range of drying hoppers is available for Gravi-Dryer® from 75-12000 litres, all with interior finish in stainless steel AISI 304.

Each drying hopper has individual temperature controller, where desired drying temperature is consistently monitored via solid state relays.

All Labotek drying hoppers comes with airtight dry air ducting system, separate over-temperature thermostat and standard floor stand.



DH 1600

Alternatively the drying hopper may fit directly in a mezzanine construction above the processing machine. Drying Hoppers are equipped with symmetrical load cells for precise weighing.



Airflow regulation valve (AFRS)

*The DFD is fitted with frequency inverter and will auto adapt to the process in accordance with material consumption.*

*Each Gravi-Dryer® has an adaptive airflow regulation valve, which will operate in accordance with consumption.*

*Gravi-Dryer® only uses the energy required for the actual consumption, providing rapid return of investment (ROI).*

*The Gravi-Dryer® hopper is including a load cell assembly where the actual and target weight of material is constantly monitored against the desired throughput.*

# Technical Data

## Gravi-Dryer® product selection key

Description	LT no.	Description	LT no.	Description	LT no.
<b>Labo-Net</b>		<b>Option: Gravi-Dryer® for DH</b>		<b>Option: Inverter for Frequency DFD</b>	
Labo-Net 62/12"	101382	DH 15-100	208710	DFD 300-450	Standard
		DH 200-300	208775		
Labo-Net 93/12"	101384	DH 450-800	208711	DFD 600-1700	206675
Combi Module, each DH 75-12000	207217	DH 1200-12000	208709		

## DH Dimensions

Type	DH 75	DH 100	DH 200	DH 300	DH 450	DH 600	DH 800
A	700	700	930	910	1165	1165	1165
B	506	506	730	700	876	876	876
C	940	1160	1120	1467	1490	1868	2118
D	1720	1940	1893	2240	2263	2641	2891
E	780	780	773	773	773	773	773
F	700	700	700	900	900	1000	1000
G	800	800	875	845	934	934	934

All Measurements are stated in mm.

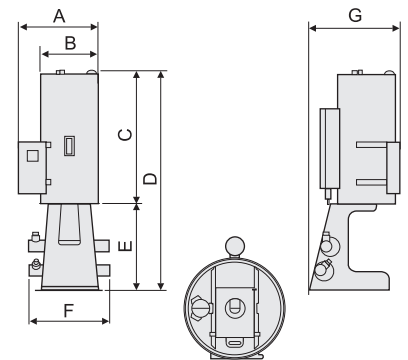

Lid DH 200-800

Type	DH 1200	DH 1600	DH 2000	DH 2500	DH 3000	DH 4000	DH 6000	DH 8000	DH 10000	DH 12000
A	890	890	1116	1116	1116	1349	1605	1605	1605	1605
B	930	931	918	918	918	918	920	920	920	920
C	2289	2899	2523	2966	3076	3354	3555	4198	4887	5380
D	1112	1112	1431	1431	1431	1708	2068	2068	2068	2068
E	664	664	697	697	697	694	704	704	704	704
F	Ø 13	Ø 13	Ø 13	Ø 13	Ø 13	Ø 18	Ø 18	Ø 18	Ø 18	Ø 18
G	1162	1162	1481	1481	1481	1775	2257	2257	2257	2257
H	1182	1182	1521	1521	1521	1772	2128	2128	2128	2128
I	824	824	1049	1049	1049	1248	1505	1505	1505	1505
J	824	824	1049	1049	1049	1248	1505	1505	1505	1505

All Measurements are stated in mm.

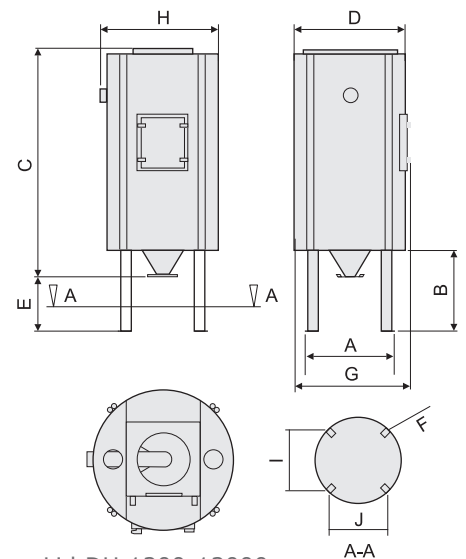

Lid DH 1200-12000

## DFD Dimensions

DFD	100-200	300-450	600	1000	1500	1700	4000	5100	6000	8500
I - Height	1600	1532	1400	1700	1700	1700	1700	1700	1700	1700
K - Width	660	854	1600	2400	2400	2400	6000	6000	8000	8000
J - Depth	720	1203	1300	1650	1650	1650	2000	2000	2000	2000

All Measurements are stated in mm.

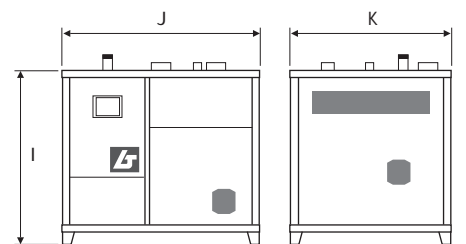

**3 years  
warranty**

Labotek offers 3 years warranty  
- excluding wear parts

**Labotek A/S**  
Stroebjergvej 29  
DK-3600 Frederikssund

+45 4821 8411  
info@labotek.dk  
www.labotek.com

Representative